



Double Trash/Recycling Container

- Dimensions: 44"W x 53 1/8"H. 210 Lbs.
- Everything except top doors are constructed of powder coated 14 Ga. CRS.
- Chute options: Trash, Bottles & Cans, Paper & Cardboard.
- Top doors are constructed of uncoated brushed 18 Ga. Stainless Steel.
- Bin door handles are recessed black plastic.
- Welded construction for superior strength.
- 36 Gallon plastic liners included.
- Zinc cam latch opens with a screwdriver instead of a key; holds doors closed, but still allows easy access.

Item #: JTA 16650

Powder Coated Finishes



Black



Brown



Blue



Forest Green



Gray

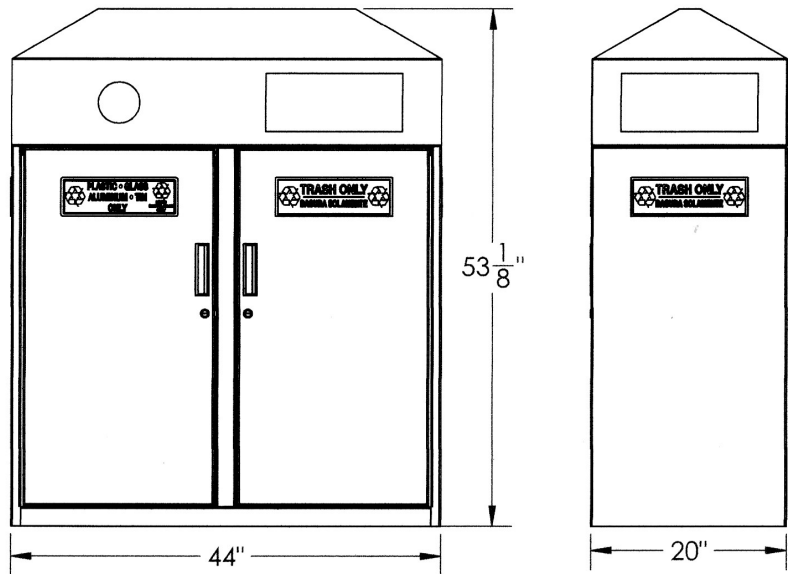

NATIONAL OUTDOOR FURNITURE, INC.
1210 W. Main Street #296 Riverhead, NY 11901
Toll-Free Phone: 1-888-663-4621
Phone: 631-369-9099 Fax: 631-207-8312
Email: nofinc@optonline.net
www.nationaloutdoorfurniture.com

NATIONAL OUTDOOR FURNITURE, INC.
144 Murdock Road #325 Pomfret Center, CT 06259
Toll-Free Phone: 1-888-516-8873
Phone: 1-860-974-1551 Fax: 516-706-1901
Email: nofinc@earthlink.net
www.nationaloutdoorfurniture.com