



**72 Gallon Dual Lexington Trash Receptacle**

- Dimensions: 37 3/8"H x 31 1/2"D x 54 3/8"W. 270 Lbs.
- UltraCoat Powder-coat finish with zinc rich base. Thirteen colors available.
- Includes two 36 gallon liners and powder coated lids.
- Optional decals are white lettering with black background.
- Portable and/or surface mount. Inground mounting kit available.
- Five Year Limited Warranty.

**Item #:** US LX-72

**Standard Powder Coat Colors**

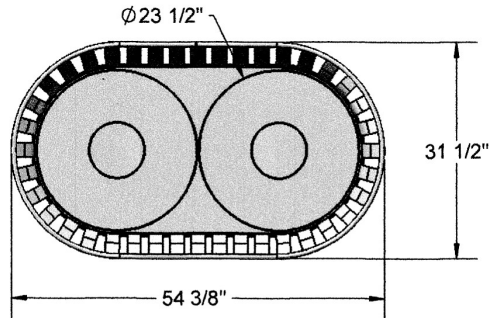

**Flat Top**

**Ash Urn**

**Rain Bonnet**

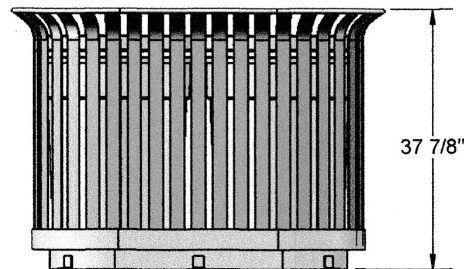

**NATIONAL OUTDOOR FURNITURE, INC.**  
 1210 W. Main Street #296 Riverhead, NY 11901  
 Toll-Free Phone: 1-888-663-4621  
 Phone: 631-369-9099 Fax: 631-207-8312  
 Email: [nofinc@optonline.net](mailto:nofinc@optonline.net)  
[www.nationaloutdoorfurniture.com](http://www.nationaloutdoorfurniture.com)

**NATIONAL OUTDOOR FURNITURE, INC.**  
 144 Murdock Road #325 Pomfret Center, CT 06259  
 Toll-Free Phone: 1-888-516-8873  
 Phone: 1-860-974-1551 Fax: 516-706-1901  
 Email: [nofinc@earthlink.net](mailto:nofinc@earthlink.net)  
[www.nationaloutdoorfurniture.com](http://www.nationaloutdoorfurniture.com)