



46" Kensington Table with (3) Attached Seats.

- 240 Lbs.
- Dimensions: 73 7/16"dia. x 30"Ht. Seats are 18 5/16"Ht.
- Solid table top is 46" diameter with 38" slat concave seats.
- Frame is 1 5/8" O.D. x 14 gauge pre-galvanized structural steel tubing.
- Coated with zinc rich epoxy primer and top coated with electrostatic powdercoat, oven cured.
- Holes are predrilled in legs for optional surface mounting.
- All electrically MIG welded.
- All MIG welded frame with walk thru design.

Item #: US 42-RDS

Standard Powder Coat Colors

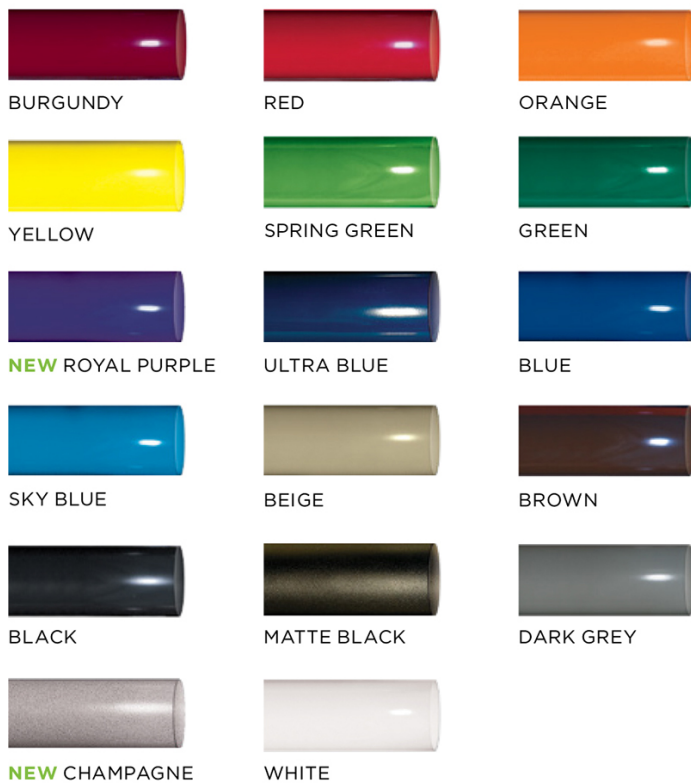

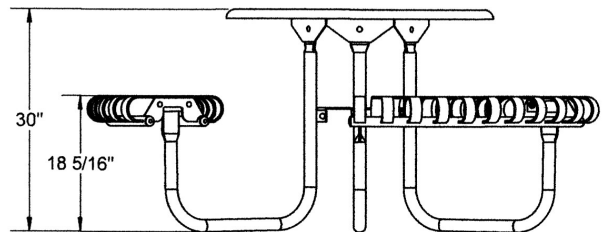
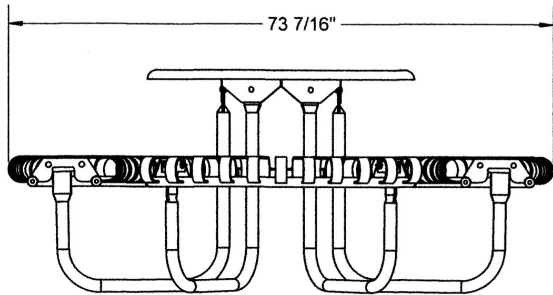
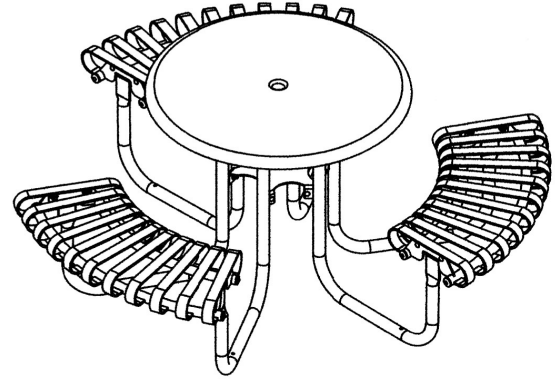
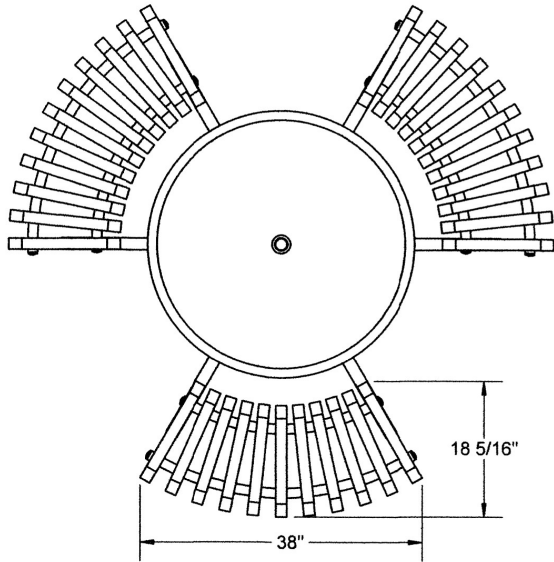

NATIONAL OUTDOOR FURNITURE, INC.

1210 W. Main Street #296 Riverhead, NY 11901
 Toll-Free Phone: 1-888-663-4621
 Phone: 631-369-9099 Fax: 631-207-8312
 Email: nofinc@optonline.net
www.nationaloutdoorfurniture.com

NATIONAL OUTDOOR FURNITURE, INC.

144 Murdock Road #325 Pomfret Center, CT 06259
 Toll-Free Phone: 1-888-516-8873
 Phone: 1-860-974-9996 Fax: 516-706-1901
 Email: nofinc@earthlink.net
www.nationaloutdoorfurniture.com