

N.O.F. / Inc.



46" Square Preschool Picnic Table -Portable. Diamond Style

- Table height is 20". Seat height is 12".
- Overall Dimensions: 77 1/2" x 77 1/2" Square. 173 Lbs.
- Tops and seats are 11 gauge die formed angle frame 1" x 1 7/8" with 3" radius corners. Polyethylene coated.
- 1-5/8" O.D. x 14 gauge pre-galvanized structural steel tubing. Electrically MIG welded.
- Stainless steel and zinc coated hardware fasteners.
- Electrostatic powder coated application oven cured frame.
- Available in expanded diamond and perforated style.
- Cross braces 1.029"O.D. x 15 gauge pre-galvanized structural steel tubing.
- Some assembly required.

Item #: US 358PS-PLP

Table Styles

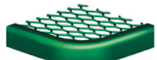

Diamond

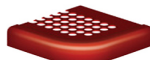

Perforated

Thermoplastic Colors



Ultra Blue



Burgundy



Green



Beige



Blue



Red



Brown



Black

Standard Powder Coat Colors



BURGUNDY



RED



ORANGE



YELLOW



SPRING GREEN



GREEN



NEW ROYAL PURPLE



ULTRA BLUE



BLUE



SKY BLUE



BEIGE



BROWN



BLACK



MATTE BLACK



DARK GREY



NEW CHAMPAGNE



WHITE

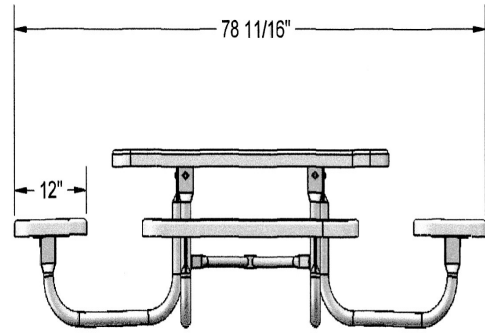
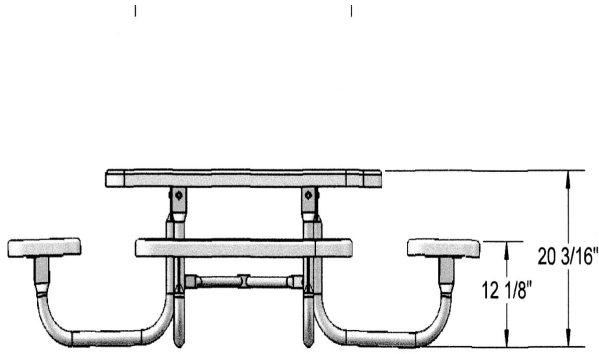

NATIONAL OUTDOOR FURNITURE, INC.
1210 W. Main Street #296 Riverhead, NY 11901
Toll-Free Phone: 1-888-663-4621
Phone: 631-369-9099 Fax: 631-207-8312
Email: nofinc@optonline.net
www.nationaloutdoorfurniture.com

NATIONAL OUTDOOR FURNITURE, INC.
144 Murdock Road #325 Pomfret Center, CT 06259
Toll-Free Phone: 1-888-516-8873
Phone: 1-860-974-9996 Fax: 516-706-1901
Email: nofinc@earthlink.net
www.nationaloutdoorfurniture.com