



12' Heavy Duty Shelter ADA Picnic Table, Centered - Portable.

- Overall Dimension: 144" x 62" x 30"H.
- 12" extension on both ends for ADA compliancy.
- All MIG welded frame with zinc or galvanized plated hardware.
- Frame available in 2 3/8" O.D. pipe with 1 15/16" O.D. brace.
- Predrilled holes for surface mounting.
- Zinc coated, galvanized, powder coated finish or galvanized frame.
- Available in Untreated Pine, Treated Pine, Redwood Stained Pine Planks.
- Some assembly required.

Item #: US 238H-3

| Model Number | Description |
|----------------|--|
| US 238H-3-U12 | 12' ADA Picnic Table, 296 Lbs., Untreated Pine. |
| US 238H-3-PT12 | 12' ADA Picnic Table, 296 Lbs., Treated Pine. |
| US 238H-3-T12 | 12' ADA Picnic Table, 296 Lbs. Redwood Stained Pine. |



Wood Planks

2" x 10" and 2" x 4" sizes
Rounded Edges
#1 Southern Yellow Pine

(U) Untreated
(PT) Pressure Treated
Environmentally Friendly ACQ
Kiln Dried Before & After Treatment
(T) Treated Stain
Sealed in Redwood Stain With
Wood Preservative

Standard Powder Coat Colors

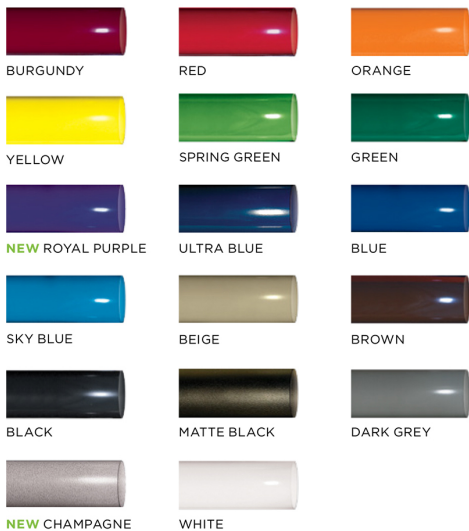

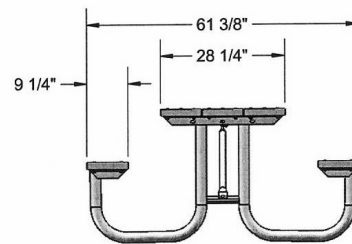
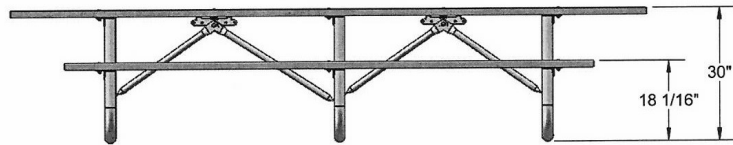
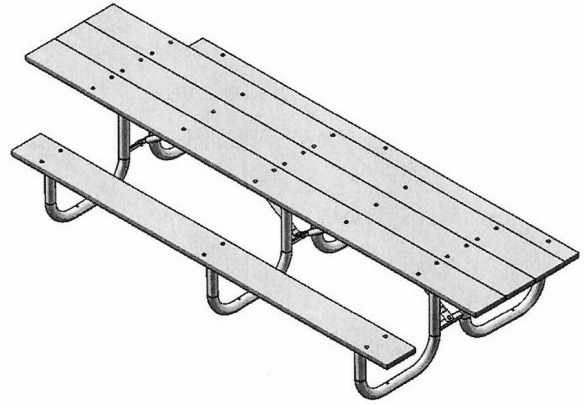
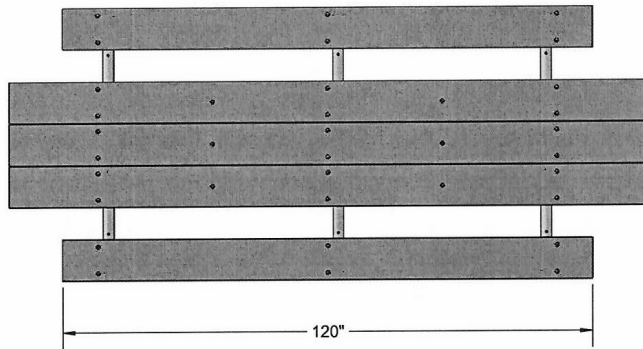

NATIONAL OUTDOOR FURNITURE, INC.

1210 W. Main Street #296 Riverhead, NY 11901
 Toll-Free Phone: 1-888-663-4621
 Phone: 631-369-9099 Fax: 631-207-8312
 Email: nofinc@optonline.net
www.nationaloutdoorfurniture.com

NATIONAL OUTDOOR FURNITURE, INC.

144 Murdock Road #325 Pomfret Center, CT 06259
 Toll-Free Phone: 1-888-516-8873
 Phone: 1-860-974-9996 Fax: 516-706-1901
 Email: nofinc@earthlink.net
www.nationaloutdoorfurniture.com