



**6' Recycled Plastic Picnic Table with (2) Attached Seats, Galvanized Frame - Portable.**

- 230 lbs.
- Dim: 72"W x 69 3/8"D x 30"H - Top is 3/4"D.
- Table top and seats are made with 2" x 10" recycled plastic slats. 2 3/8" O.D. galvanized frame.
- All holes are predrilled and countersunk for plastic lumber.
- Includes a UV protectant.
- Maintenance free.
- No umbrella hole.
- Table top and seats available in green, cedar, brown and gray with galvanized or black powder coated frames.

Some assembly required.

NOF# JP PB6GFPIC

Model Number	Description
JP PB6GFPIC	6 Ft. Table 230 Lbs.
JP PB8GFPIC	8 Ft. Table 270 Lbs.

## Resinwood Slat Colors



Cedar



Brown



Gray

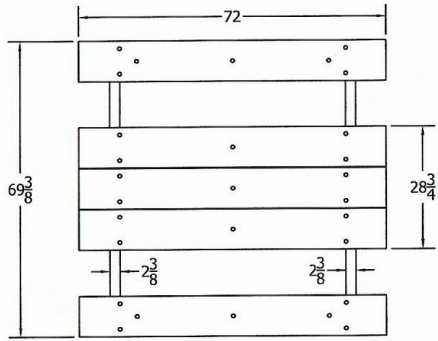

TOP VIEW

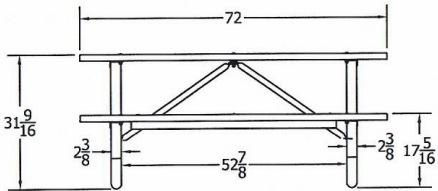

FRONT VIEW

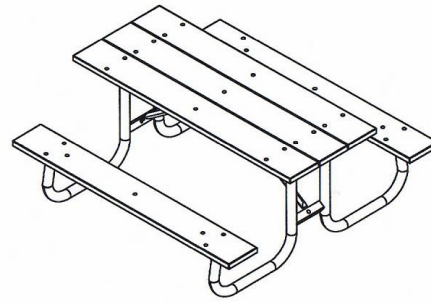

3D ISOMETRIC VIEW

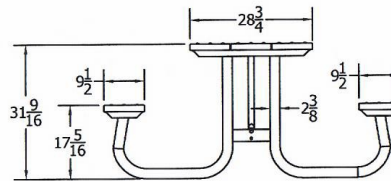

SIDE VIEW

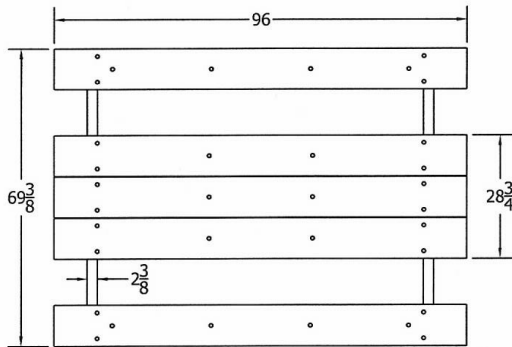

TOP VIEW

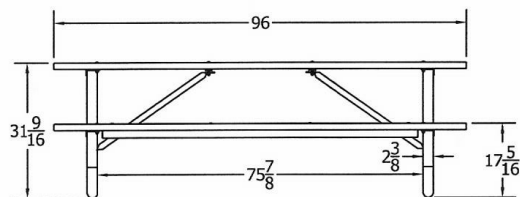

FRONT VIEW

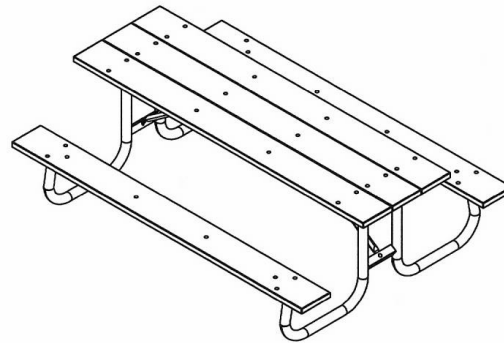

3D ISOMETRIC VIEW

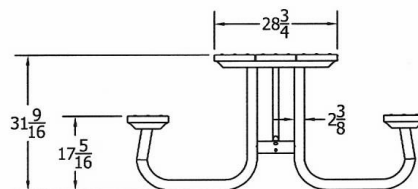

SIDE VIEW

**NATIONAL OUTDOOR FURNITURE, INC.**

1210 W. Main Street #296. Riverhead, NY 11901  
 Toll-Free Phone: 1-888-663-4621  
 Phone: 631-369-9099 Fax: 631-207-8312  
 Email: [nofinc@optonline.net](mailto:nofinc@optonline.net)  
[www.nationaloutdoorfurniture.com](http://www.nationaloutdoorfurniture.com)

**NATIONAL OUTDOOR FURNITURE, INC.**

144 Murdock Road #325 Pomfret Center, CT 06259  
 Toll-Free Phone: 1-888-516-8873  
 Phone: 1-860-974-1551 Fax: 516-706-1901  
 Email: [nofinc@earthlink.net](mailto:nofinc@earthlink.net)  
[www.nationaloutdoorfurniture.com](http://www.nationaloutdoorfurniture.com)