



32 Gallon Animal Resistant Single Trash Receptacle

- Dimensions: 22 1/2"W x 40"D x 51 1/2"H. 190 Lbs.
- Door hinges are heavy duty stainless steel for superior corrosion resistance and longevity.
- Uses one standard 32 gallon recycle type bag.
- Animal resistant internal single point self latching system on service latch.
- Welded 14 gauge construction.
- 3/16" thick mounts with (4) holes bored to fit 1/2" bolts.
- All exposed corners are chamfered for safety.
- 5 Powder coated colors available for superior corrosion protection.

Item #: JTA 13595-32

Powder Coated Finishes

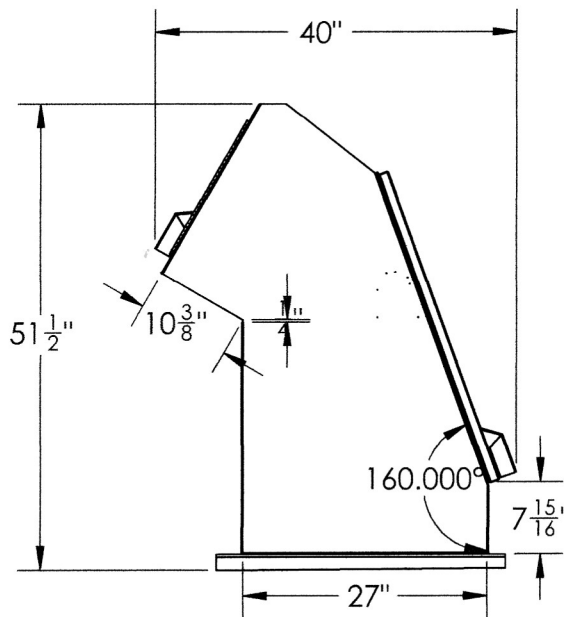
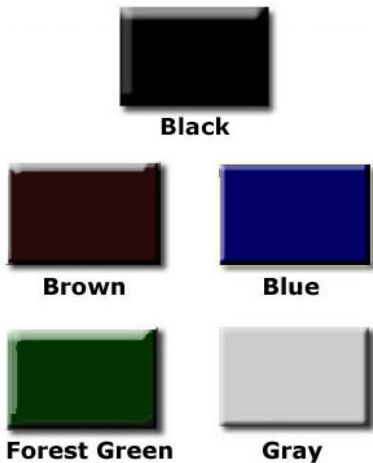

ESTIMATED WEIGHT: 190 LBS

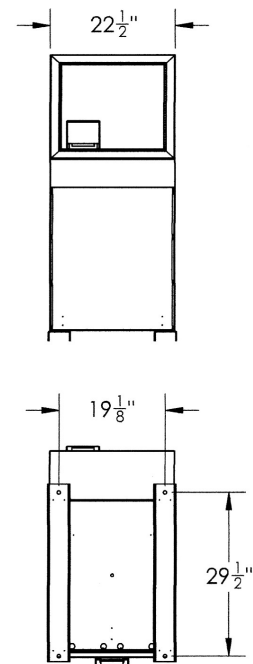

NATIONAL OUTDOOR FURNITURE, INC.

1210 W. Main Street #296 Riverhead, NY 11901
 Toll-Free Phone: 1-888-663-4621
 Phone: 631-369-9099 Fax: 631-207-8312
 Email: nofinc@optonline.net
www.nationaloutdoorfurniture.com

NATIONAL OUTDOOR FURNITURE, INC.

144 Murdock Road #325 Pomfret Center, CT 06259
 Toll-Free Phone: 1-888-516-8873
 Phone: 1-860-974-1551 Fax: 516-706-1901
 Email: nofinc@earthlink.net
www.nationaloutdoorfurniture.com