



**Hex Recycled Plastic Picnic Table with (3) Attached Seats, ADA - Portable.**

- 210 lbs.
- Dim: 72" x 72" Overall Width x 41 1/2"D Top.
- Made with 100% recycled plastic slats and recycled plastic base.
- All holes are predrilled and countersunk for plastic lumber.
- Includes a UV protectant.
- Maintenance free.
- With umbrella hole.
- Available in gray, green or cedar top/seats with black base.

**Item #:** JP PB6HEXADA

## Resinwood Slat Colors



Cedar



Green



Gray



Brown

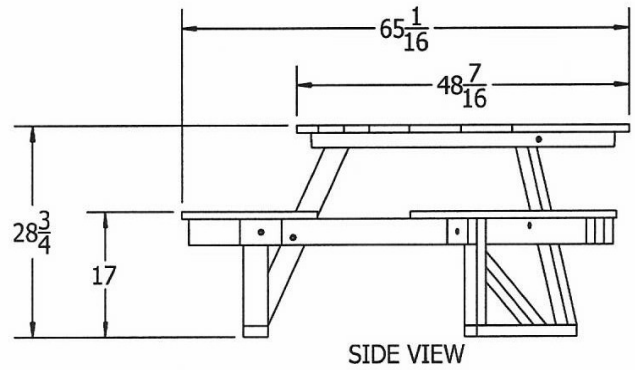
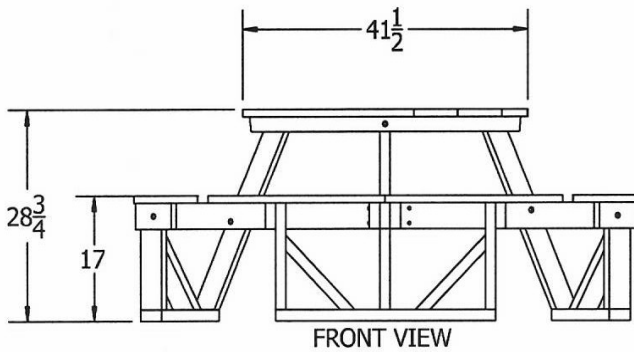
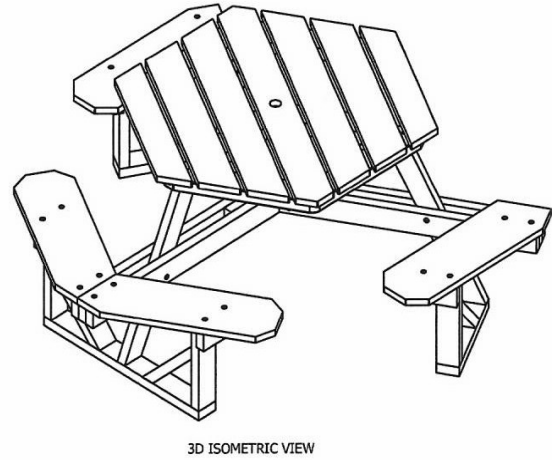
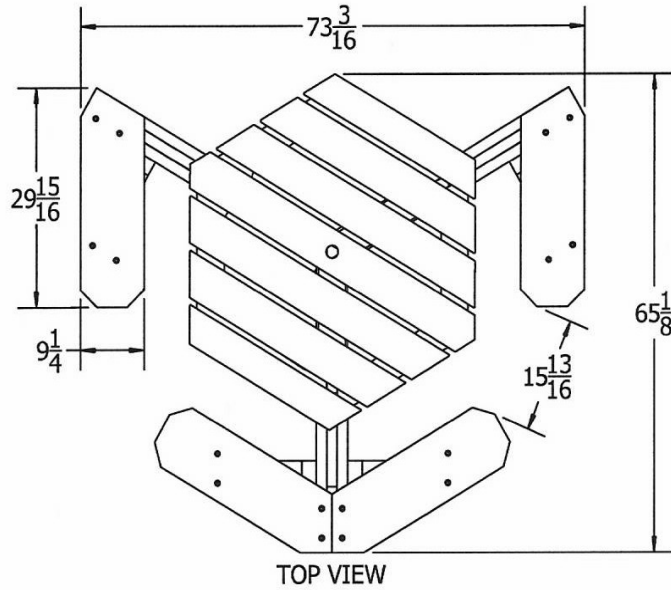

**NATIONAL OUTDOOR FURNITURE, INC.**  
 1210 W. Main Street #296 Riverhead, NY 11901  
 Toll-Free Phone: 1-888-663-4621  
 Phone: 631-369-9099 Fax: 631-207-8312  
 Email: [nofinc@optonline.net](mailto:nofinc@optonline.net)  
[www.nationaloutdoorfurniture.com](http://www.nationaloutdoorfurniture.com)

**NATIONAL OUTDOOR FURNITURE, INC.**  
 144 Murdock Road #325 Pomfret Center, CT 06259  
 Toll-Free Phone: 1-888-516-8873  
 Phone: 1-860-974-9996 Fax: 516-706-1901  
 Email: [nofinc@earthlink.net](mailto:nofinc@earthlink.net)  
[www.nationaloutdoorfurniture.com](http://www.nationaloutdoorfurniture.com)