



**7 1/2' Recycled Plastic Picnic Table with (2) Attached 6' Seats, ADA - Portable.**

- 335 lbs.
- Dim: 90"W x 57"D x 28 1/2"H - Top is 28"D.
- Table top and seats are made with 2" x 10" recycled plastic slats and black recycled plastic base.
- All holes are predrilled and countersunk for plastic lumber.
- Includes a UV protectant.
- Maintenance free.
- No umbrella hole.
- Table top and seats available in green, cedar, brown and gray with black base.
- Some assembly required.

**Item #:** JP PB6PARKPADA

**Resinwood Slat Colors**



Cedar



Green



Gray



Brown

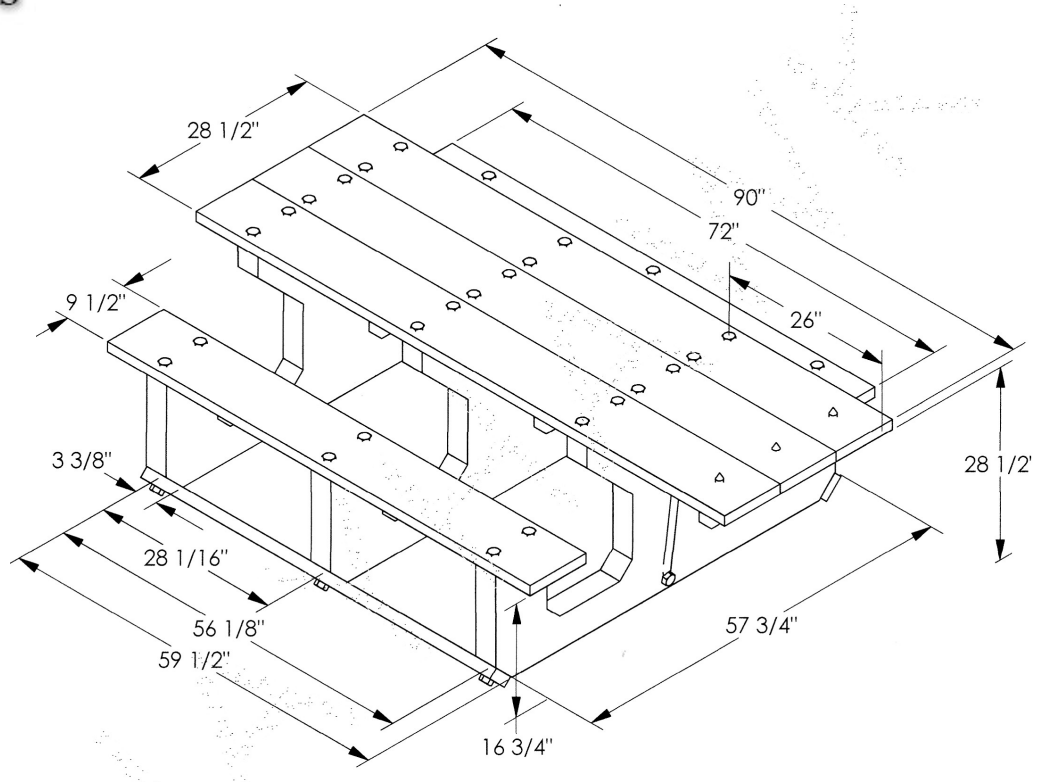

**NATIONAL OUTDOOR FURNITURE, INC.**

1210 W. Main Street #296 Riverhead, NY 11901  
 Toll-Free Phone: 1-888-663-4621  
 Phone: 631-369-9099 Fax: 631-207-8312  
 Email: [nofinc@optonline.net](mailto:nofinc@optonline.net)  
[www.nationaloutdoorfurniture.com](http://www.nationaloutdoorfurniture.com)

**NATIONAL OUTDOOR FURNITURE, INC.**

144 Murdock Road #325 Pomfret Center, CT 06259  
 Toll-Free Phone: 1-888-516-8873  
 Phone: 1-860-974-9996 Fax: 516-706-1901  
 Email: [nofinc@earthlink.net](mailto:nofinc@earthlink.net)  
[www.nationaloutdoorfurniture.com](http://www.nationaloutdoorfurniture.com)