

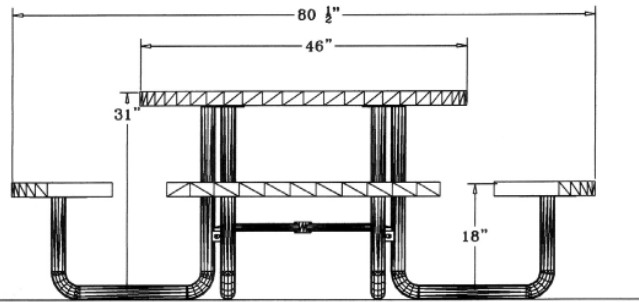

**46" Round Canteen Table with (4) Attached Concave, Solid Top - Portable.**

- 239 lbs.
- Polyethylene coated solid top.
- 3/4" #9 Polyethylene expanded metal seats inside a 2" x 2" x 1/8" angle iron frame.
- 1 5/8" Zinc coated, powder coated galvanized steel frame.
- With umbrella hole.
- Surface and inground mounting clamps available.
- Some assembly required.

**NOF#:** WC RSRD46P



**Regal Style Portable**

**Portable Table Mounting Options**



Surface Mounting Clamp



Inground Mounting Clamp

**Textured Polyethylene Colors**



**Powder Coat Gloss Finishes**



**Thermoplastic Color Options**



National Outdoor Furniture  
1210 W. Main Street #296  
Riverhead, N.Y. 11901

PHONE (888) 663-4621  
E-MAIL [nofinc1@gmail.com](mailto:nofinc1@gmail.com)

[www.nationaloutdoorfurniture.com](http://www.nationaloutdoorfurniture.com)