



48" Square ADA Picnic Table with (3) Seats - Portable.

- Overall Dimensions: 74 1/2" x 74 1/2" x 29 15/16" H.
- Wood style or aluminum style 2" x 10" planks.
- 1 5/8" O.D. frame. Bolt together walk thru design.
- Zinc coated, galvanized, powder coated finish or galvanized frame.
- Available in Untreated Pine, Treated Pine, Redwood Stained Pine and Aluminum Planks.
- Predrilled holes for surface mounting.
- Available as an ADA table with 2 seats.
- Some assembly required.

Item #: US 358H



Wood Planks

2" x 10" and 2" x 4" sizes
Rounded Edges
#1 Southern Yellow Pine

(U) Untreated
 (PT) Pressure Treated
 Environmentally Friendly ACQ
 Kiln Dried Before & After Treatment
 (T) Treated Stain
 Sealed in Redwood Stain With
 Wood Preservative

Model Number	Description
US 358H-U48	48' ADA Table, 184 Lbs., (3) Attached Seats, Untreated Pine, Portable.
US 358H-PT48	48' ADA Table, 184 Lbs., (3) Attached Seats, Treated Pine, Portable.
US 358H-T48	48' ADA Table, 184 Lbs., (3) Attached Seats, Redwood Stain, Portable.

Standard Powder Coat Colors

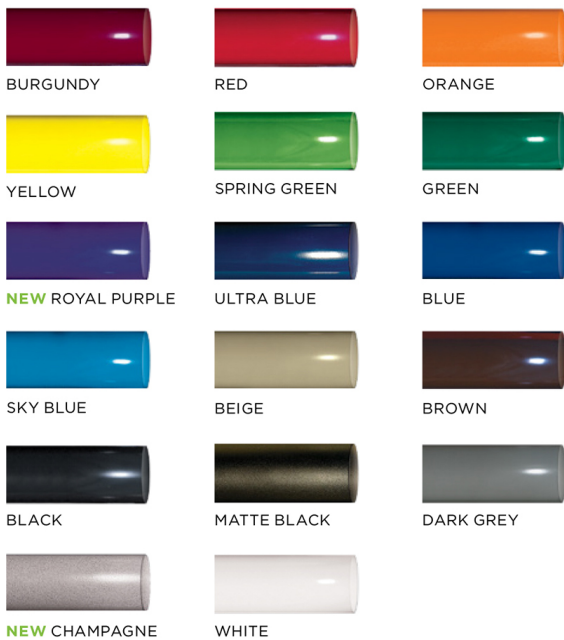

National Outdoor Furniture
 1210 W. Main Street #296
 Riverhead, N.Y. 11901

PHONE (888) 663-4621
 E-MAIL nofinc1@gmail.com
www.nationaloutdoorfurniture.com

48" ADA Square Table, (3) Seats

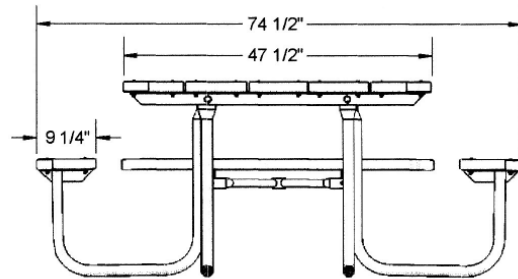
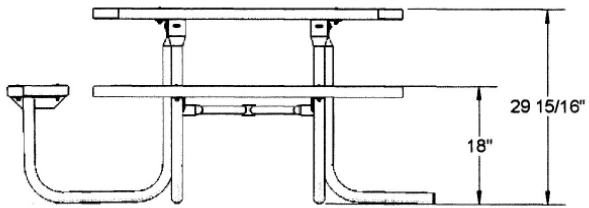
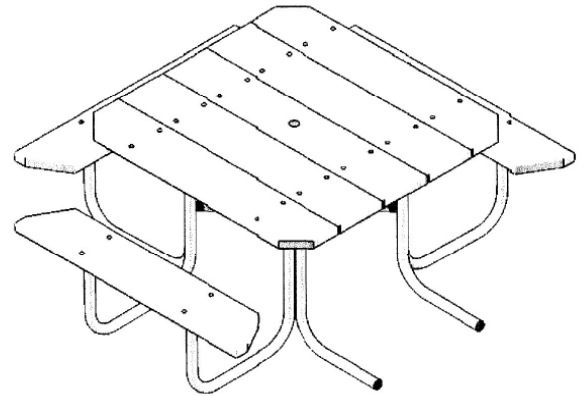
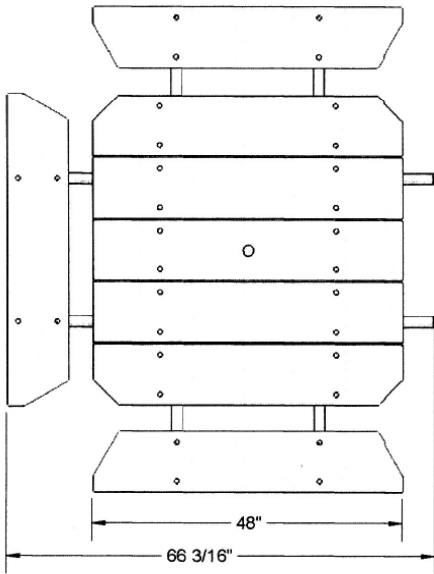

National Outdoor Furniture
1210 W. Main Street #296
Riverhead, N.Y. 11901

PHONE (888) 663-4621
E-MAIL nofinc1@gmail.com

www.nationaloutdoorfurniture.com