



12' Heavy Duty Shelter ADA Picnic Table, Centered - Portable.

- Overall Dimension: 144" x 62" x 30"H.
- 12" extension on both ends for ADA compliancy.
- All MIG welded frame with zinc or galvanized plated hardware.
- Frame available in 2 3/8" O.D. pipe with 1 15/16" O.D. brace.
- Predrilled holes for surface mounting.
- Zinc coated, galvanized, powder coated finish or galvanized frame.
- Available in Untreated Pine, Treated Pine, Redwood Stained Pine Planks.
- Some assembly required.

Item #: US 238H-3



Wood Planks

2" x 10" and 2" x 4" sizes
Rounded Edges
#1 Southern Yellow Pine

(U) Untreated
(PT) Pressure Treated
Environmentally Friendly ACQ
Kiln Dried Before & After Treatment
(T) Treated Stain
Sealed in Redwood Stain With
Wood Preservative

Model Number	Description
US 238H-3-U12	12' ADA Picnic Table, 296 Lbs., Untreated Pine.
US 238H-3-PT12	12' ADA Picnic Table, 296 Lbs., Treated Pine.
US 238H-3-T12	12' ADA Picnic Table, 296 Lbs. Redwood Stained Pine.

Standard Powder Coat Colors

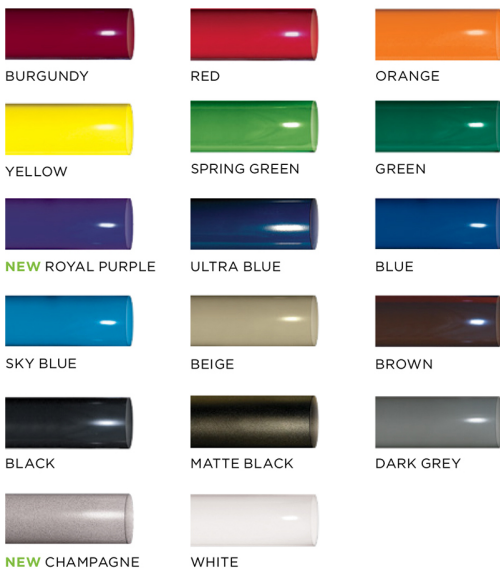

National Outdoor Furniture
1210 W. Main Street #296
Riverhead, N.Y. 11901

PHONE (888) 663-4621
E-MAIL nofinc1@gmail.com
www.nationaloutdoorfurniture.com

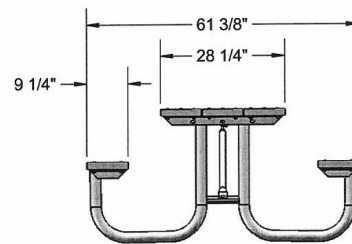
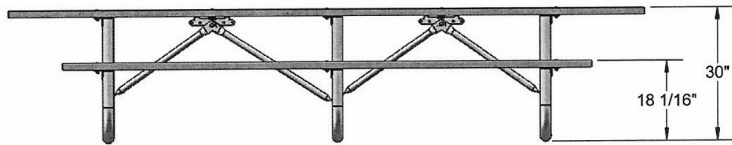
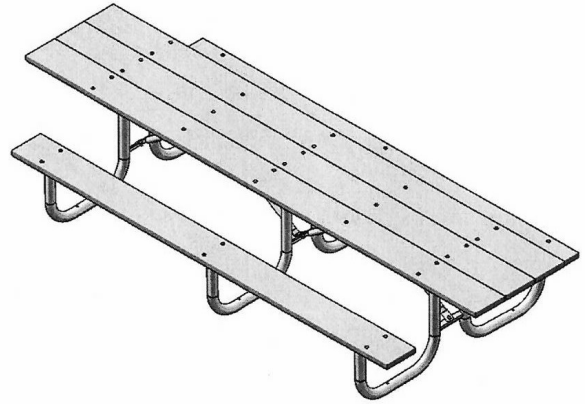
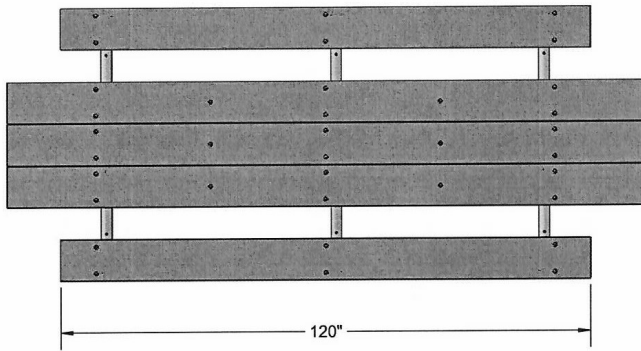

National Outdoor Furniture
1210 W. Main Street #296
Riverhead, N.Y. 11901

PHONE (888) 663-4621
E-MAIL nofinc1@gmail.com
www.nationaloutdoorfurniture.com