



64 Gallon Animal Resistant Dual Trash Receptacle

- Dimensions: 41 1/2"W x 40"D x 51 1/2"H. 285 Lbs.
- Door hinges are heavy duty stainless steel for superior corrosion resistance and longevity.
- Uses two standard 32 gallon recycle type bag.
- Animal resistant internal single point self latching system on service latch.
- Welded 14 gauge construction.
- 3/16" thick mounts with (4) holes bored to fit 1/2" bolts.
- All exposed corners are chamfered for safety.
- 5 Powder coated colors available for superior corrosion protection.

Item #: JTA 13407

Powder Coated Finishes



Black



Brown



Blue



Forest Green



Gray



National Outdoor Furniture
1210 W. Main Street #296
Riverhead, N.Y. 11901

PHONE (888) 663-4621
E-MAIL nofinc1@gmail.com

www.nationaloutdoorfurniture.com

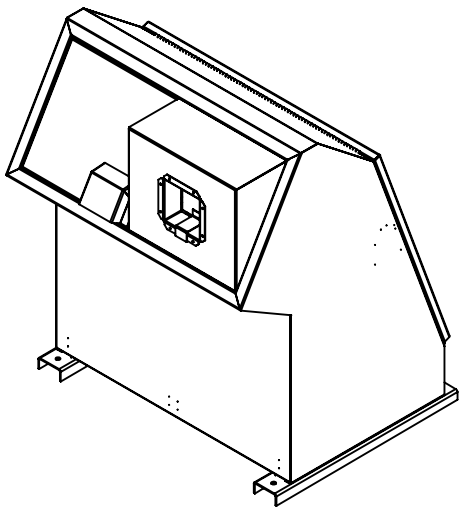

MODEL 13407 64 GALLON CAPACITY ANIMAL RESISTANT TRASH/RECYCLE RECEPTACLE

- Uses two standard 32 gallon recycle type bags.
- ADA compliant.
- Easy access top loading chutes.
- Pivoting bag racks for easy trash removal.

Mechanical specifications

- Door hinges are heavy duty stainless steel for superior corrosion resistance and longevity.
 - Animal resistant internal single point self latching system on service hatch.
 - Welded 14 gauge construction.
 - 3/16" thick mounts with (4) holes bored to fit 1/2" bolts.
 - Powder coated for superior corrosion protection.
- Available in forest green, blue, brown, and gray.

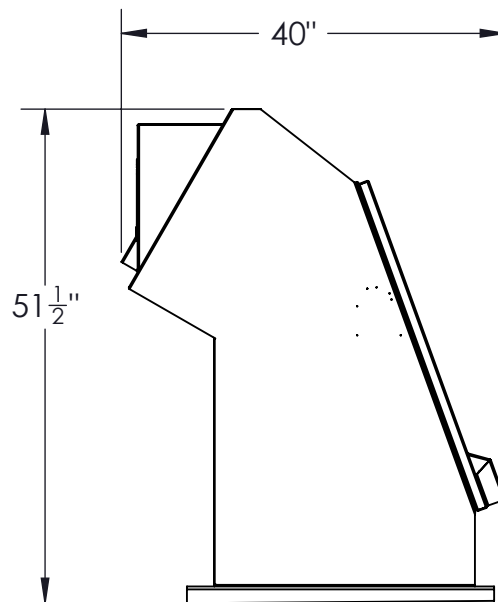
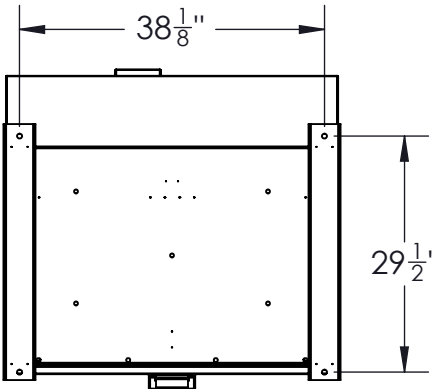
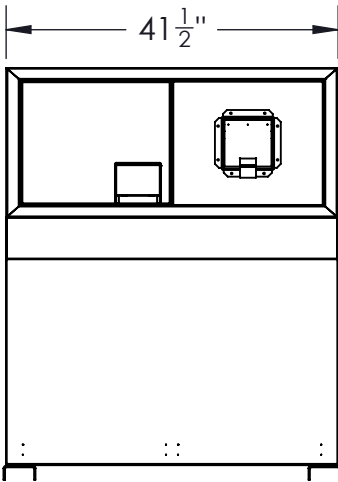

ESTIMATED WEIGHT: 285 LBS