



Double Trash/Recycling Container

- Dimensions: 44"W x 53 1/8"H. 210 Lbs.
- Everything except top doors are constructed of powder coated 14 Ga. CRS.
- Chute options: Trash, Bottles & Cans, Paper & Cardboard.
- Top doors are constructed of uncoated brushed 18 Ga. Stainless Steel.
- Bin door handles are recessed black plastic.
- Welded construction for superior strength.
- 36 Gallon plastic liners included.
- Zinc cam latch opens with a screwdriver instead of a key; holds doors closed, but still allows easy access.

Item #: JTA 16650

Powder Coated Finishes



Black



Brown



Blue



Forest Green



Gray

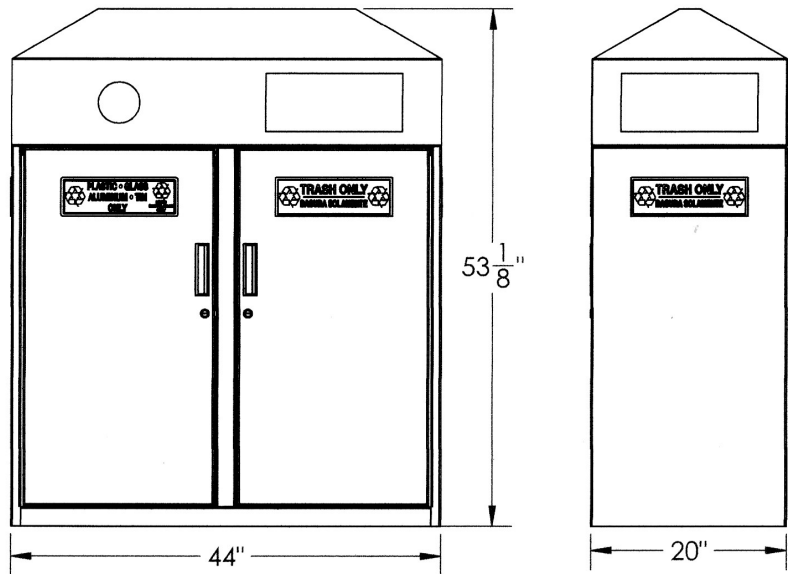

National Outdoor Furniture
1210 W. Main Street #296
Riverhead, N.Y. 11901

PHONE (888) 663-4621
E-MAIL nofinc1@gmail.com

www.nationaloutdoorfurniture.com